Set Up PON Distribution Cabinet

Summary of PON FTTH Networks

PON (Passive Optical Networking) has become a very popular deployment technique for Fiber-To-The-Home (FTTH) networks since it radically reduces the cost and complexity of operating the network by eliminating the need for active devices in the field. Instead, all active devices (optical transmitters, receivers, etc.) are located in a centralized facility (usually called a Hub) that may serve many thousands of customers.

To utilize fiber capacity efficiently, PON networks usually employ multiplexing of some kind, so that multiple customers (32 being a common number) actually share the same forward-path signal. Part of the provisioning process for the Customer Premise Equipment (CPE) selects which of the channels carried by the PON fiber connected to the CPE is intended for that device.

Multiplexing in this way allows all of the premises that are fed from different channels on the same MUX circuit to be *concentrated* onto a single fiber. This makes the utilization of fiber much more efficient as, instead of having to run a single fiber (carrying just one channel) from the hub to each premise, a large number of homes (32 in our typical example) can all share the same fiber back to the hub.

Although the fiber back to the hub is shared among many customers, the network must still be designed so that each premise is associated with a dedicated distribution fiber. To distribute the signal to individual dwellings, the fibers from the hub (*Feeder fibers*) typically terminate at a small, neighborhood cabinet called a *Local Convergence Cabinet* (also called a *Local Concentration Cabinet*, or *Local Concentration Point*). This cabinet contains passive splitter modules which passively split the optical signal from fibers in the feeder cable into some number of copies (32 in our example) of the initial signal. Each copy is then fed to a *Distribution* cable which connects the LCC to each home the LCC serves. An LCC which has 18 x 32 way splitters (and therefore requires 18 feeder fibers from the hub) can serve up to 576 homes (since $18 \times 32 = 576$).

A diagram summarizing the typical PON FTTH physical network architecture is shown below.

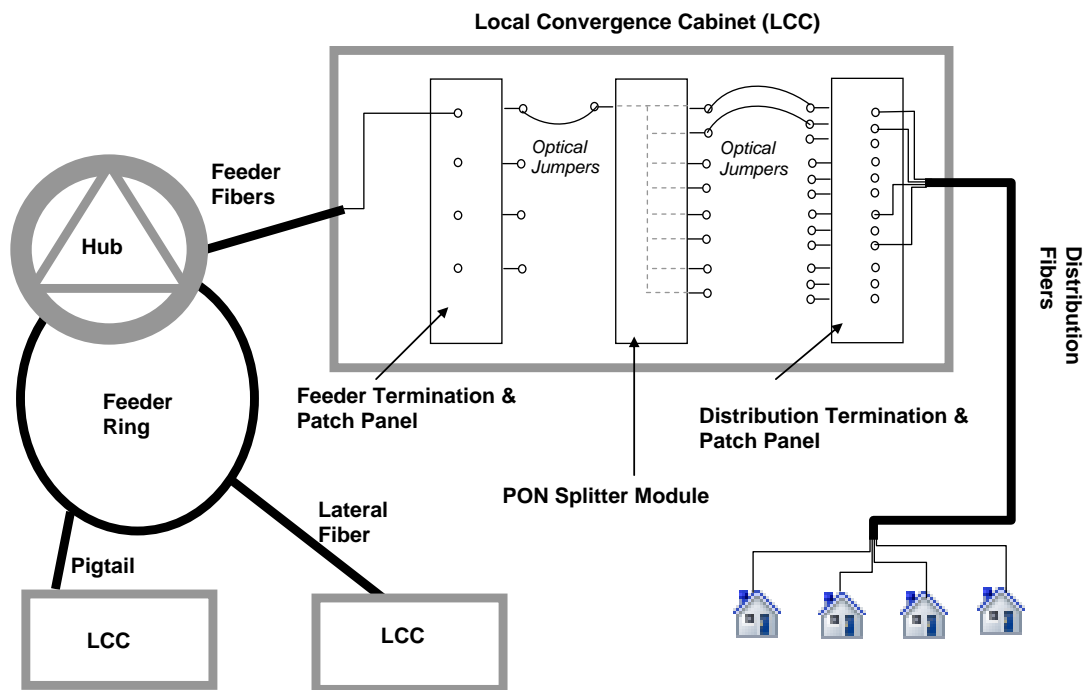

Figure 1 – Typical PON FTTH Physical Network Architecture

Modeling a PON LCC Cabinet in SPATIALnet

In this section, we shall review how SPATIALnet can best be used to model the LCC, whose logical layout is illustrated above.

This can be done by following the steps listed below. Before proceeding, make sure you have the following objects already configured in the various dictionaries. If you need to create dictionary entries for any of the following types of equipment, please see your local administrator, or consult the *SPATIALnet Configuration Guide*.

Dictionary Items That Must be Configured to Model an LCC Cabinet.

1. A Site Type for the PON cabinet (Site Dictionary).
2. Configure OSP terminations in the Fiber Dictionary for the fiber terminations on the Feeder side and Distribution sides of the LCC (Fiber Term Panel Dictionary)
3. In the ISP dictionary, configure:
 - a. Patch panels for the OSP fiber terminations.
 - b. The splitter module (and a chassis for it, if required)
 - c. Port Mappings from the IN port to each of the OUT ports of the splitter.

Building the LCC/LCP

Building the LCC/LCP in SPATIALnet consists of the following steps:

1. Place the ISP Site at the location of the LCC/LCP
2. Place a rack on the site floor.
3. Place the Feeder side fiber termination and patch panel (usually an ISP Chassis)
4. Place the Distribution side fiber termination and patch panel (again, usually an ISP Chassis)
5. Place the required number of splitter modules.
6. Connect each splitter's IN port to a port on the feeder patch panel
7. As required (usually, when customer's request service), connect an available OUT port on one of the splitter modules to a port on the distribution patch panel.

Note that SPATIALnet's ISP Clone function can replace the steps 1 to 5 with a single click. Rather than building a new LCC/LCP from scratch, an existing LCC that has been configured to match the LCC/LCP you wish to build can be selected and "Cloned" (Select the ISP site you wish to clone, open its Details panel, then click the Clone button). Cloning includes copying all internal devices, plan drawings and connections.

When OSP fiber is connected on the feeder and distribution sides, this will set up a physically traceable circuit between each connected premise and the hub.

1. ISP site placement and floor creation.

To place the ISP site representing the LCC/LCP:

1. Click the **Add Site** button on either the Fiber or ISP toolbars. (make sure the **Capable of modeling ISP equipment** checkbox is set). Fill in the fields appropriately.
2. Click on the location in the map at which you wish to place the new LCC/LCP. This may appear similar to that shown below.

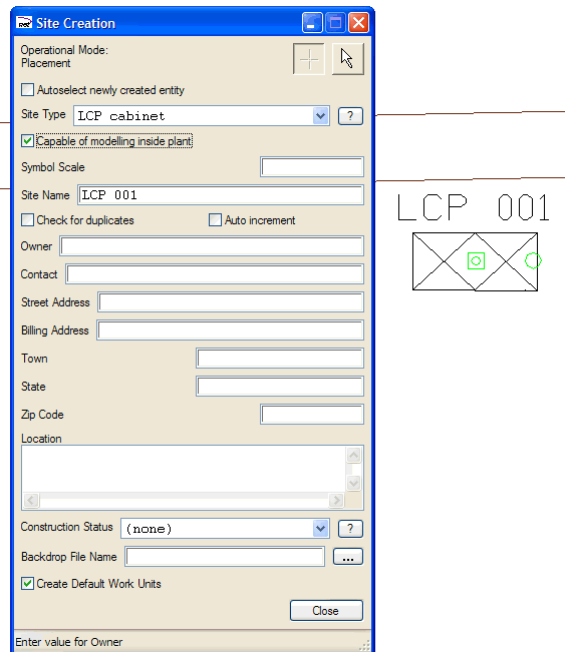

Figure 2 – Placing a new ISP site to represent the LCC/LCP

To function correctly in SPATIALnet, each ISP Site needs at least one floor, and to house equipment, it must have at least one “rack”-class device on that floor into which equipment may be placed.

To place the floor:

1. Select the LCC/LCP by clicking on it.
2. Open its Details panel.
3. Click the **Add** button and select **Add a Floor to the Selected Site** from the pop-up, as shown below.

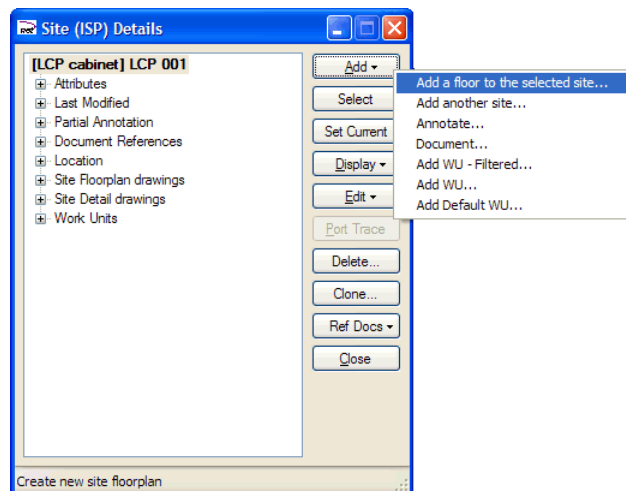

Figure 3 – Adding the floor to the LCC/LCP

2. Place Rack on floor

Before any devices can be placed in the new cabinet, or fiber connected to it, a rack must be placed on the floor in order to contain devices and provide a termination point for the fiber. In most cases, the "rack" placed in the cabinet represents the cabinet housing itself. If a drawing of such a housing is available, then mount points can be added to it and it can be registered as the Elevation View representation of the rack (see the *SPATIALnet Configuration Manual*). An example of a typical cabinet drawing that can be used in this way is shown below:

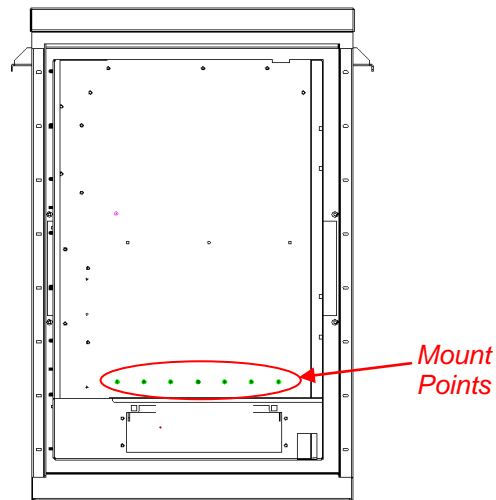

Figure 4 – Typical rack elevation view of LCC/LCP before internal equipment added.

To place the rack on the floor in the LCC/LCP:

1. Select the Floor in the details panel for the cabinet, click the **Add** button, and select **Add a rack to the selected site floor...** from the pop-up, as shown below.

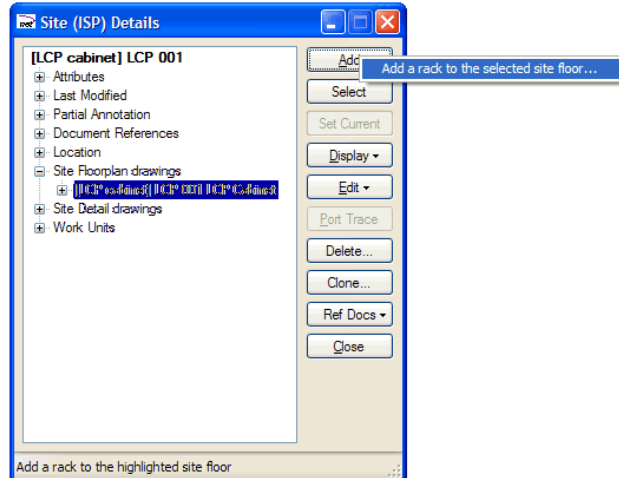

Figure 5 – Select the floor in the site details panel and click Add to place a new rack.

2. Fill in the fields on the Create Rack panel as required.

3. Place the Feeder side fiber termination and patch panel

To terminate the outside plant Feeder fiber at the cabinet, a patch panel must be placed in the rack. The patch panel should be configured as an ISP device (usually a chassis). To indicate that this device is capable of terminating outside plant fiber, the OSP Link field in the ISP Dictionary entry for that device should be set to an OSP fiber termination panel whose number of ports matches the number of ports on the ISP patch panel (see the *SPATIALnet Configuration Manual* for more details).

To place the fiber patch panel (and associated fiber termination infrastructure) in the rack:

1. Select the rack.
2. Click the Add Chassis button on the Add ISP toolbar, or run the ISP > Add > Chassis menu command.
3. Click the Select button on the Add Chassis panel to select the dictionary entry for the Feeder Termination panel for an LCC/LCP.
4. Provide a name for this device (e.g. FEEDER TERMINATION) and click the Add button.

4. Place the Distribution side fiber termination and patch panel

The procedure for placing the distribution side termination and patch panel is identical to placing the feeder side panel, except that in step 3, the dictionary entry for the distribution side panel should be selected. This normally has a much larger number of ports than the feeder side.

5. Place the required number of splitter modules

As described in the overview of the PON network architecture, signal from each of the feeder fibers is split into multiple signals to feed the distribution network. This is achieved by placing splitter modules into the cabinet. Each splitter is usually fed by a single feeder fiber (but this is not necessarily the case), and has output ports for many distribution fibers (32 is a typical number). Common practice is to equip each PON cabinet with a small number of splitter modules initially, and add further modules as necessary when the existing capacity within the cabinet is close to be reached. For this reason, it is important to know how many splitter modules each cabinet contains, and how many are carrying active services.

Before placing splitter modules in the cabinet, these must be configured in the ISP dictionary. Depending on the structure of the cabinet, these will be modeled either as chassis (the most common approach) or cards (also valid, assuming there is a separate chassis placed in the cabinet to hold the splitter modules).

Note that for correct tracing behavior, Port Connections must be set up in the ISP Dictionary for the splitter modules. These specify that a signal entering the IN port will propagate to each of the OUT ports.

To place the splitter module into the cabinet:

1. Select the rack.
2. Click the Add Chassis button on the Add ISP toolbar, or run the ISP > Add > Chassis menu command.
3. Click the Select button on the Add Chassis panel to select the dictionary entry for the Splitter Module.
4. Provide a name for this device (e.g. SPLITTER 01) and click the Add button.

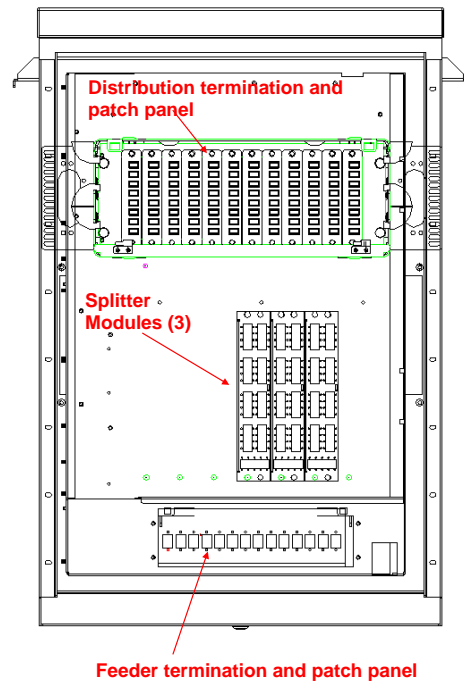

Figure 6 – Typical elevation view of LCC/LCP with all devices installed. Compare this with the schematic in Figure 1.

6. Connect each splitter's IN port to a port on the feeder patch panel

The configuration shown in Figure 6 shows a complete hardware setup for an LCC/LCP. However, there is as yet no optical connectivity from the feeder side to the distribution side. A signal entering the cabinet on a feeder fiber would not be transmitted to any of the distribution ports.

To complete the process and establish connectivity:

- Using an optical jumper, the IN port of each splitter module must be connected to an active port of the Feeder patch panel.
- For each Distribution port that is feeding an active service, an optical jumper should be created connecting that port to one of the splitter OUT ports. This will be covered in item 7, below.

To create an optical jumper that connects a feeder patch port to a splitter IN port, one of two methods may be used:

- Drag ports in a schematic diagram
- Drag and drop ports between details views.

Drag ports in a schematic diagram

To use this method, you must create a schematic diagram of the LCP. The procedure for doing this is covered under the *Inside Plant* section of the *SPATIALnet User Manual* and shown below.

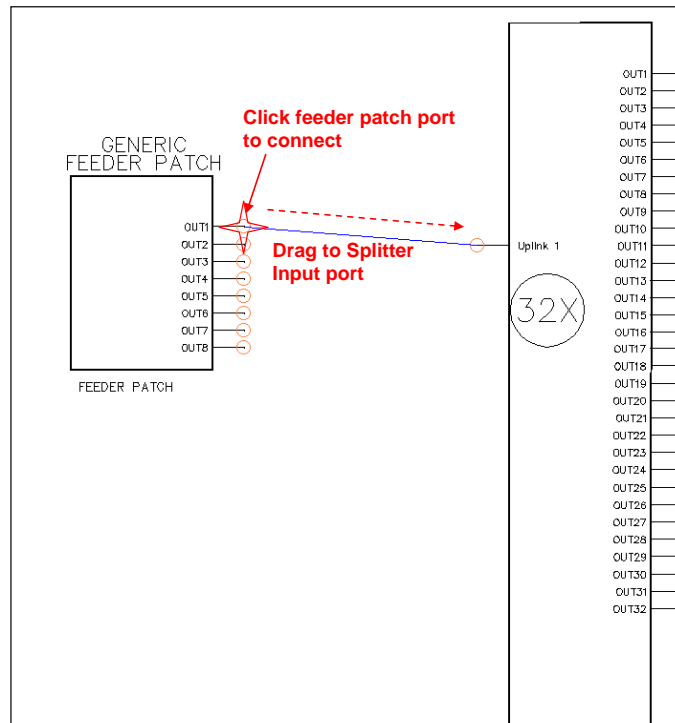

Figure 7 – Connect Feeder port to splitter input using schematic view.

Drag and ports between details panels

To use this method, you must open the details panels for both the feeder patch panel, and the splitter module. To create a jumper cable between the ports:

1. Click on one of the ports you wish to connect (say the port on the patch panel)
2. Drag this port onto the port you wish to connect to (the Uplink or Input port on the splitter panel).
3. Click on **Add a Cable between port1 and port2** on the pop-up.

This process is shown below.

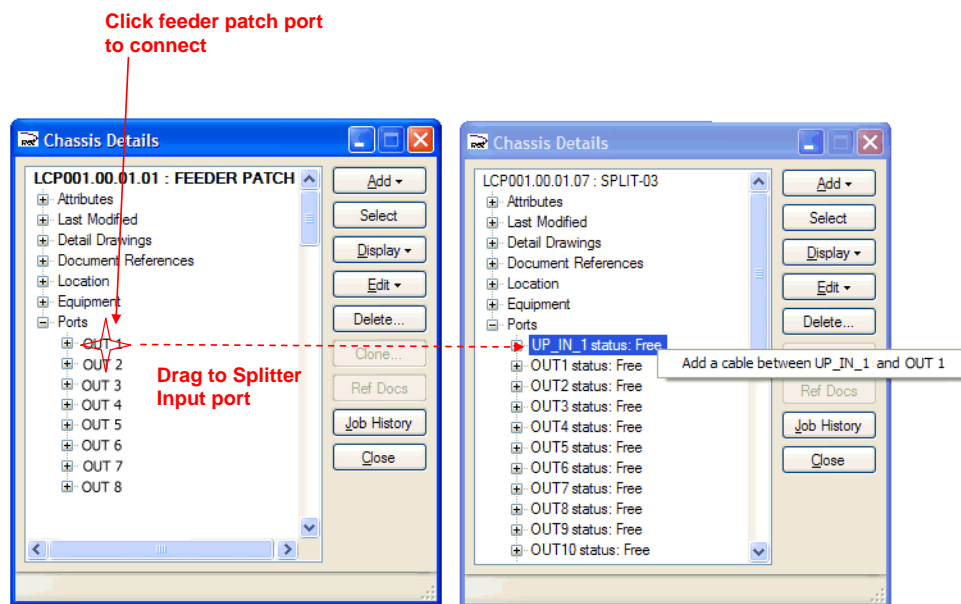

Figure 8 – Connect Feeder port to splitter input using details panels.

7. Connect splitter output ports to Distribution patch ports

The final step in modeling an operational LCC/LCP is the connection of the splitter output ports to the distribution patch ports. Recall that each distribution port provides fiber connectivity to a single dwelling (see Figure 1) and, to get signal to a dwelling, the corresponding distribution port must be connected to an output on one of the splitter modules (this creates an optical path from the dwelling back to the Hub).

Generally, unlike jumpers connecting feeder ports and splitter inputs which are installed whenever a splitter is added to the cabinet, jumper cables between distribution ports and splitter outputs are added only as customers request service. When a customer ceases service (due to voluntary or forced disconnection, moving out, etc.) it is common to leave the jumper for that house in place, and simply de-provision the CPE for that service. When a new service is subsequently established at that house, the installation process can be simplified and greatly speeded up if it is known that a jumper cable from a previous connection already exists in the LCC/LCP feeding that house. Therefore, keeping accurate records of jumpers installed in the LCC/LCPs is an important business function.

Installing jumpers between the splitter outputs and Distribution patch ports follows an identical procedure to placing jumpers between the Feeder patch ports and the splitter input described in item 6, above. The only difference is that the ports to connect are a splitter output and a Distribution patch port, rather than Feeder patch port and a splitter input.